

MAP11FMAE011

FARMNAVIGATOR

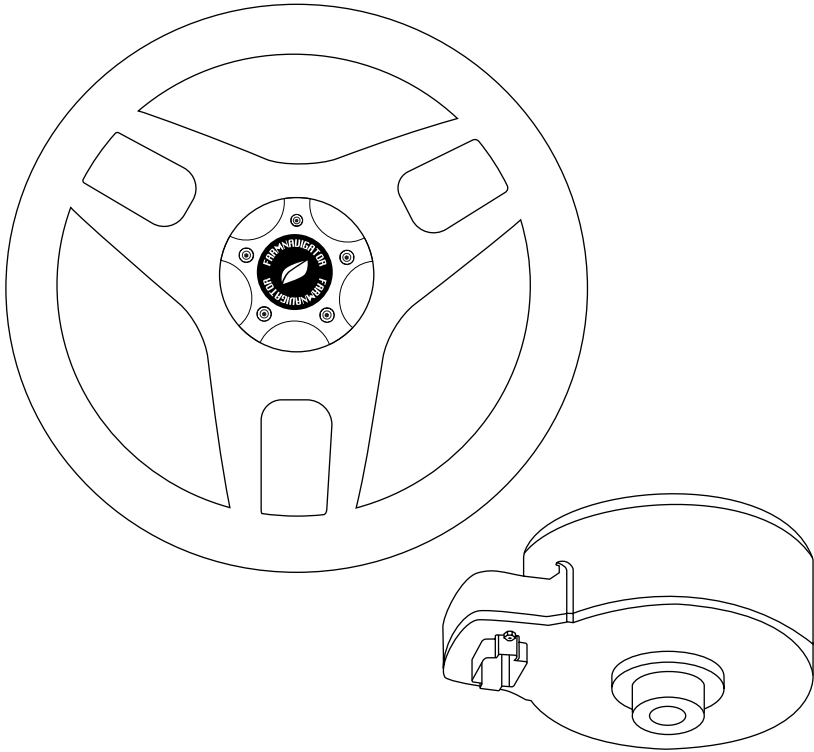

Pilota

INSTALLATION MANUAL

1. Product description

FARMNAVIGATOR Pilota is a high precision vehicle interface controller that provides additional functions and features to the FARMNAVIGATOR display (G7 / G12). In addition, FARMNAVIGATOR Pilota can receive driving information from the display and interface it with the vehicle to steer the vehicle and display the automatic steering functionality on the display.

This user manual contains information on how to set up, configure and manage the various settings of FARMNAVIGATOR Pilota. Please refer to the FARMNAVIGATOR display user manual (G7 / G12) for more information on configuring fields, farm areas, guidance patterns and other display-related functions.

FARMNAVIGATOR Pilota can be easily installed on most agricultural vehicles of all brands and models. This chapter provides basic information on the installation of the FARMNAVIGATOR Pilota components.

1.1 The system

The complete automatic steering system consists of:

- Steering system: FARMNAVIGATOR Pilota
- GNSS RTK antenna: FARMNAVIGATOR All in One RTK (not included)
- Display: FARMNAVIGATOR G7 / G12 (not included)

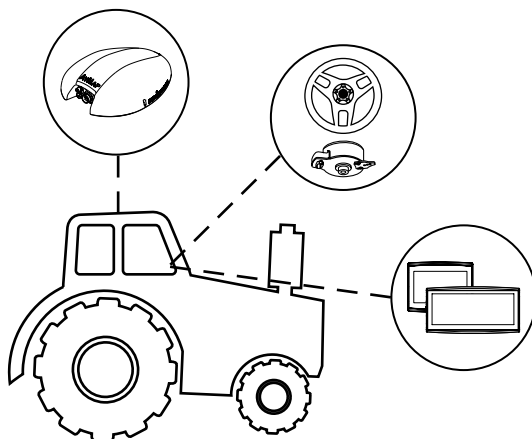

2. Installation procedure

2.1 Pilota automatic steering motor installation

This chapter explains how to connect the wiring of the automatic steering system to the vehicle. For the installation of the engine on the vehicle, suitable equipment is required for the correct removal of the steering wheel without damaging the vehicle's steering components.

Before installing the electric motor, it is a good idea to check the condition of the vehicle's steering: ensure that the steering is in good/very good condition. Ensure that it is possible to turn the steering wheel fully both right and left.

Here are described the steps for the correct installation of the electric motor:

1. Proceed, with the appropriate tools, to remove the steering wheel from the vehicle;



2. When the steering wheel has been removed, check that the motor installation kit is correct. Insert the spline adapter into the steering column and check that there is correct mechanical coupling;



3. Attach the supplied steering wheel to the engine using the 6 screws provided;



4. Attach the spline adapter to the back of the electric motor using the 6 screws provided;
CAUTION: use strong threadlocker to ensure secure fastening;



5. Attach the fixing bracket under the motor and connect the anti-rotation pin;



6. Insert the electric motor fitted with the steering wheel, spline adapter and anti-rotation pin on the vehicle's steering column and check that the coupling is well made without play;

WARNING: if too much mechanical play is noted, mechanical parts may be damaged over time and operator safety cannot be guaranteed. In this case, STOP the installation. The manufacturer is not responsible for installations that do not comply with the instructions.



7. Bracket the counterpart of the anti-rotation fastener firmly at a fixed and sturdy point on the steering column.

Keeping the vehicle stationary, turn the steering wheel to the left and right and make sure:

- There is no play in the coupling with the steering column;
- The rotation is well centered and not eccentric;
- There are no obstructions to the rotation up to the end of travel of the wheels to the right and left;
- The rotation is smooth and not subject to stresses due to the fixing of the motor.

2.2 Antenna installation

For the antenna installation, please refer to the display-specific installation manual.

These are the steps to follow:

1. Identify the attachment point for the antenna on the roof of the vehicle. TIP: Try to position the antenna as close to the front steering axle as possible;
2. Clean the antenna mounting area with a damp cloth and degreaser;
3. Fix the antenna securely using the accessories included in the display package; if it is possible to mechanically fix the antenna bracket, it is preferable, otherwise use the supplied 3M double-sided adhesive tape;
4. Route the cable firmly from the antenna to the inside of the cab near the display position;
5. Connect the antenna to the display connector "GPS".



2.3 Display installation

For display installation, please refer to the display-specific installation manual.

These are the steps to follow:

1. Fix the monitor securely using the accessories included in the display package;
2. Connect the monitor to the power supply using the wiring supplied with the display;

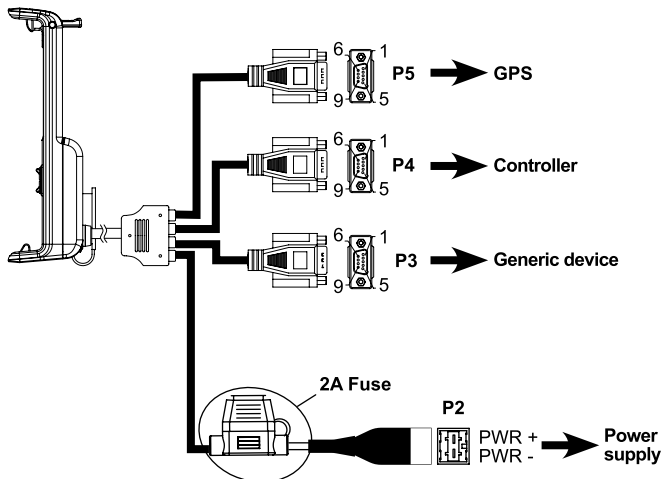

3. Connect the antenna firmly to the 'GPS' connector.

IMPORTANT: connect the 'In-CAB' cable to the display.

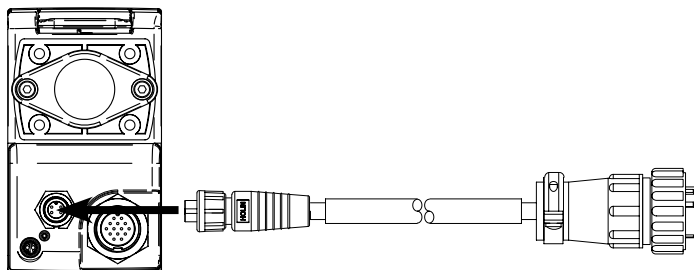
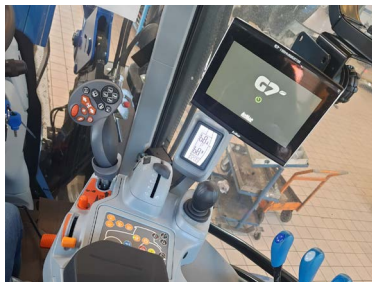

2.4 Electric connection

Here are the steps to follow for the electrical connection:

A. Pilota Battery cable

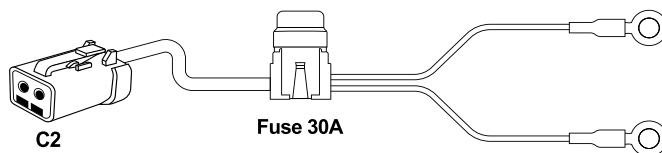

1. Locate the battery position inside the vehicle and start to route the 'Pilota battery cable'. Do not connect the terminals to the battery;
2. Bring the connector from the battery inside the vehicle. Ensure that the cable is not attached to moving mechanical elements, rubber hydraulic hoses, air conditioning pipes, high-temperature elements or in close proximity to electric alternators;
3. Connect the connector "C2" to the 'Pilota main cable' and make sure it is well connected.

B. Pilota CAN cable

Please note that the cable includes a 120 Ohm passive terminator on the CAN line.

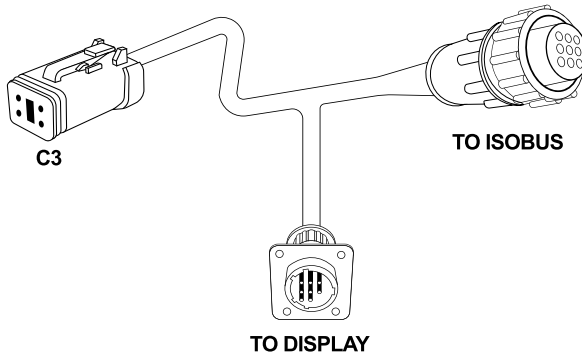

1. The 'TO DISPLAY' connector is connected to the 'In-CAB' cable of the G7 or G12 display;
2. The 'TO ISOBUS' connector remains available if ISOBUS equipment also needs to be connected to the steering system;
3. The 'C3' connector must be connected to the 'Pilota main cable';

C. Pilota main cable

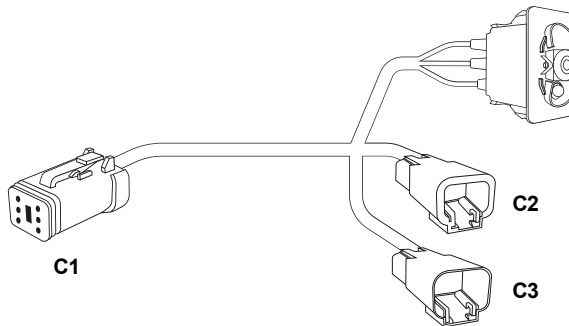

1. Connect the connector "C1" to the motor, make sure it is secure;
2. Route the cable and install the switch for deactivating the system in the street in an accessible, clearly visible and firmly fixed position;
3. Firmly connect the connector "C2" ending with the 'Pilota Battery cable';
4. Firmly connect the connector "C3" ending with the 'Pilota CAN cable';

2.5 Battery connection

Connect the system to the battery:

1. When everything is properly and securely fastened, connect the terminals to the battery;
2. First connect the negative (black) connector to the battery terminal.

CAUTION: do not connect negative connector to bolts or vehicle body parts;

3. Connect the positive (red) connector to the battery terminal.

CAUTION: if a battery isolator is fitted, it is recommended to connect the positive connector to the battery isolator connector.

3. Automatic steering setup and calibration procedure

After all components have been installed, it is necessary to configure and calibrate the components on the vehicle. In fact, each vehicle has different geometric dimensions and hydraulic characteristics, therefore, a calibration of the sensors should be performed following the procedures described below. Please follow the instructions provided precisely to obtain a correct driving result that conforms and is safe to the product specifications.

3.1 Creating a new vehicle

For the automatic steering system to work properly, the vehicle must be configured.

Vehicle configuration consists of entering the geometric measurements of the vehicle and the position of the antenna relative to the center of the vehicle and the rear axle of the vehicle.

Here are the steps:

1. The “VEHICLES” menu is accessed from the DATABASE menu.



Figure 3.1.a - Vehicles menu

2. Create a new vehicle by assigning a unique name;
3. Follow the screen and enter all required values. Be careful to select correctly if:
 - The antenna is installed in front or behind the rear axle;
 - The antenna is installed to the right or left of the vehicle's center axle;
 - Antenna measurements should be referred to the three indicators shown on the antenna plastic, the front one for the center and the side ones for the position of the antenna relative to the rear axis.

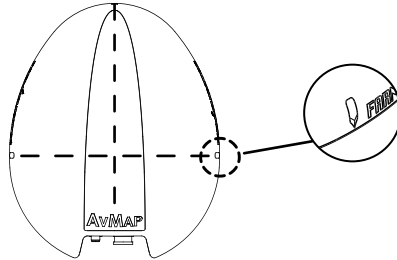

Figure 3.1.b - Indicators for measurement on the antenna

- Measurements should be entered with an accuracy of +/-1 cm to ensure optimal results in the field.

VEHICLE
 KUBOTA
Active

01	Front to rear axle	2.30 m	✓
02	Height	2.50 m	✓
03	Antenna lateral shift	0.00 m	✓
04	Rear axle to antenna	1.20 m	✓
05	Rear axle to trailer hitch	0.50 m	✓
06	Rear axle to 3 points hitch	0.50 m	✓
07	Min turning radius	5.00 m	✓

Antenna	
<input checked="" type="checkbox"/> Forward	
<input type="checkbox"/> Backward	

Antenna	
<input type="checkbox"/> Left	
<input checked="" type="checkbox"/> Right	

Activate

Delete

Figure 3.1.c - Vehicle geometric measurements

- Once the measurements have been entered, activate the vehicle by pressing the “ACTIVATE” button. The active vehicle can be recognized by a green check mark next to the name.

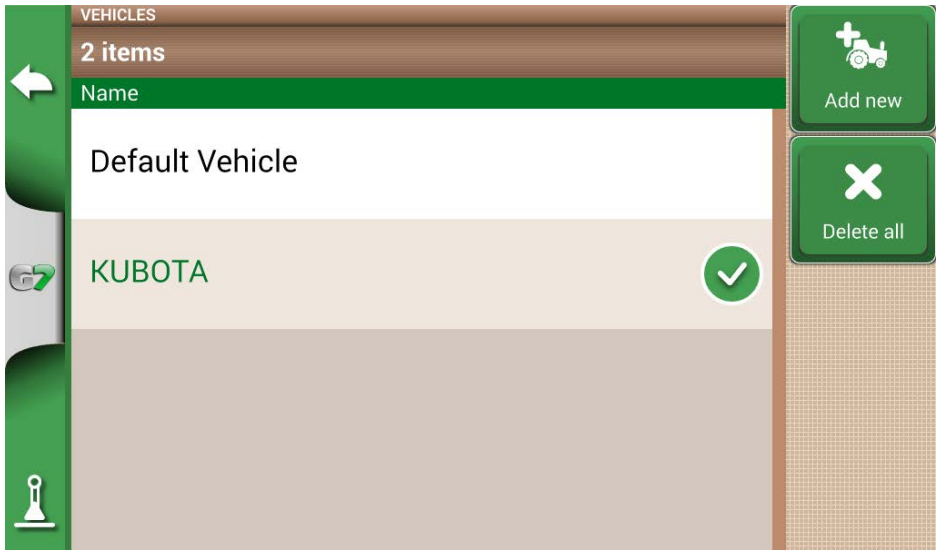

Figure 3.1.d - The new vehicle is active

At this point, the unit uses the provided geometric configurations for both automatic steering and all other applications (ISOBUS, section control, etc.).

3.2 Antenna sensor calibration

A key component of the automatic steering system is the position sensor, which is the antenna that receives the position. The antenna includes an inertial platform that enables the vehicle to drive and maintain the driving direction and position accurately. It is very important to perform calibration accurately. Calibration must be performed:

- On a perfectly flat surface;
- With the vehicle engine running but in parking position (P);
- Without attached implement.

From the SETUP > SATELLITES > TERRAIN COMPENSATION menu, activate compensation by selecting ON and then “Start calibration.”

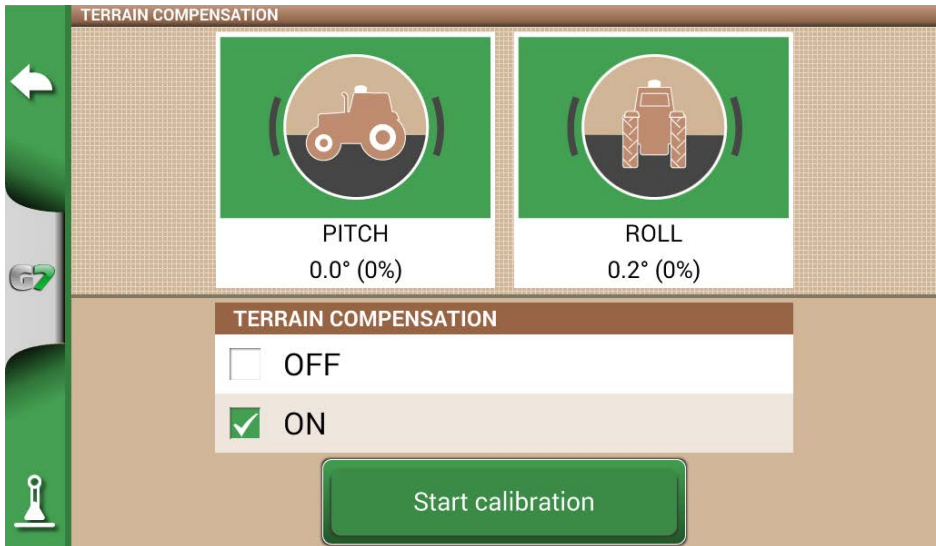

Figure 3.2.a - Terrain compensation activation and calibration start

The calibration is divided into two parts:

1. Part 1: Place the vehicle on a perfectly flat surface, in the parking position (P). Then press “Set zero level 1.”

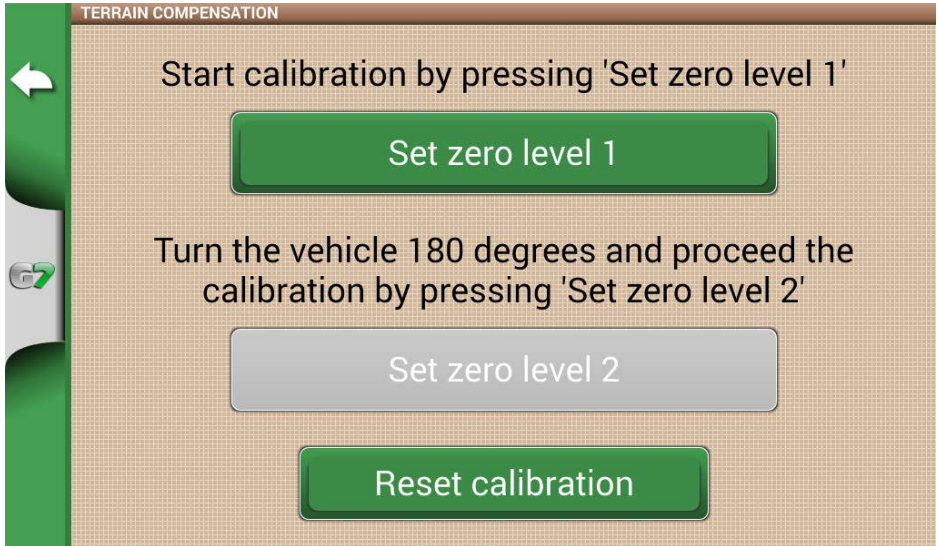

Figure 3.2.b - Set zero level 1

2. Confirm the setting of the new zero level by pressing YES.



Figure 3.2.c - Confirmation of zero level setting

3. Wait 10 seconds until completion.

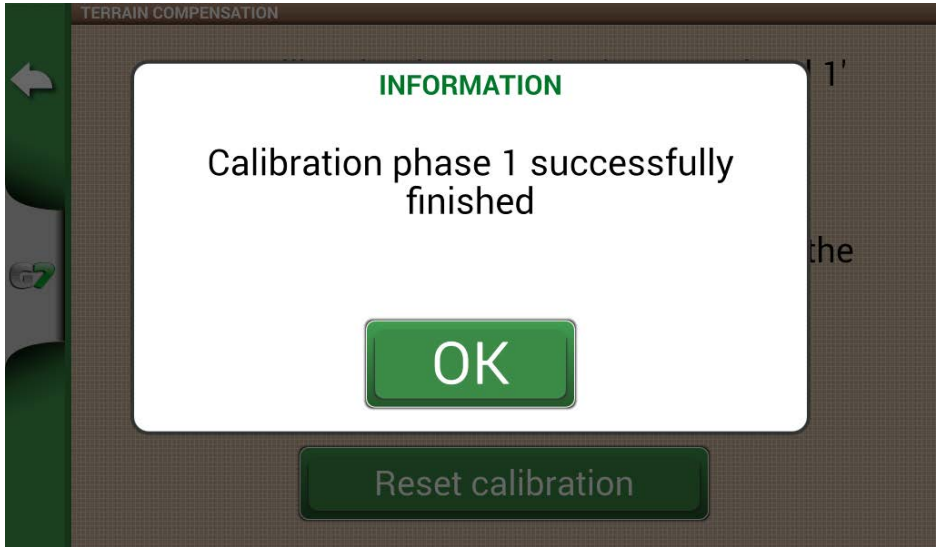

Figure 3.2.d - Wait for the completion of step 1

4. Part 2: Move the vehicle and rotate 180° from the previous position and reposition to the same spot.

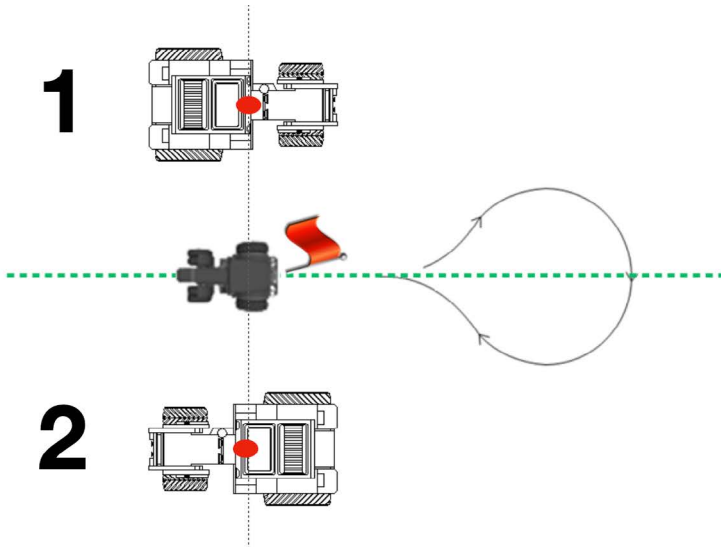

Figure 3.2.e - Rotate the vehicle 180°

5. Put yourself in park (P) and press “Set zero level 2.”

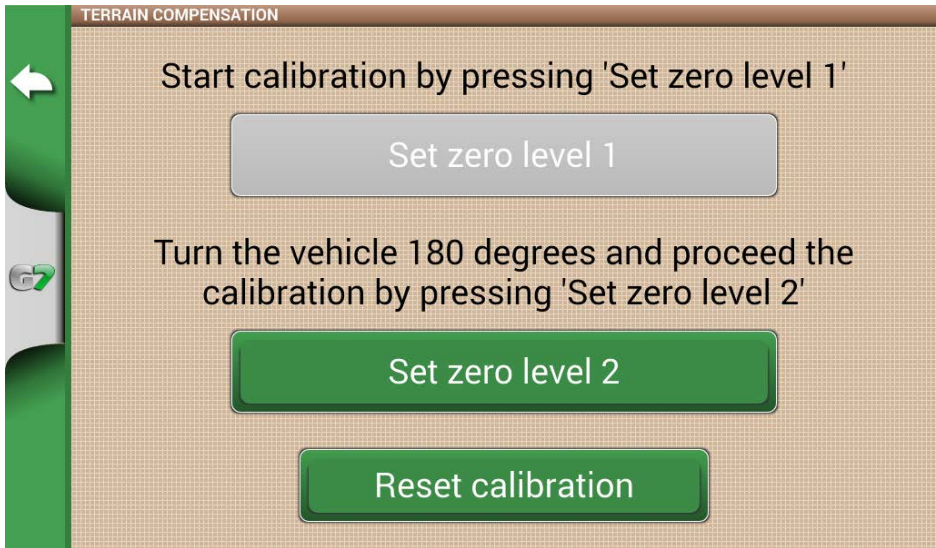

Figure 3.2.f - Set zero level 2

6. Wait 10 seconds until calibration is complete.

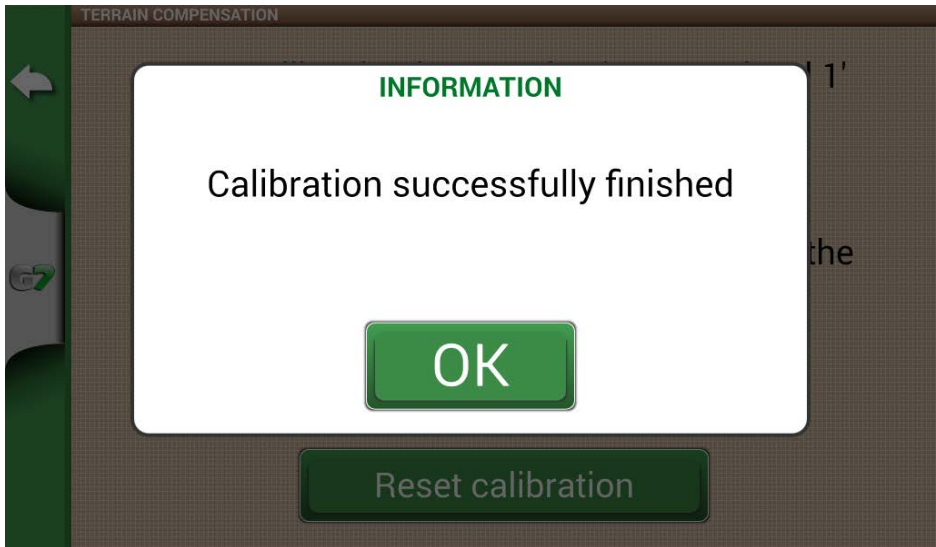

Figure 3.2.g - Successfully completed calibration

7. At this point the antenna is calibrated.

Please note that each time the antenna position is changed or modified, the calibration steps must be performed again.

3.3. Motor dead band calibration

Dead band calibration allows you to determine the minimum value needed to turn the steering wheel.

Calibration must be performed:

- On a perfectly flat surface (possibly concrete);
- With the vehicle engine running;
- Without attached implement;
- With electric motor powered on.

From the SETUP > Auto steering menu, select DEAD BAND CALIBRATION.

1. Press Start, DO NOT TOUCH the steering wheel during calibration;

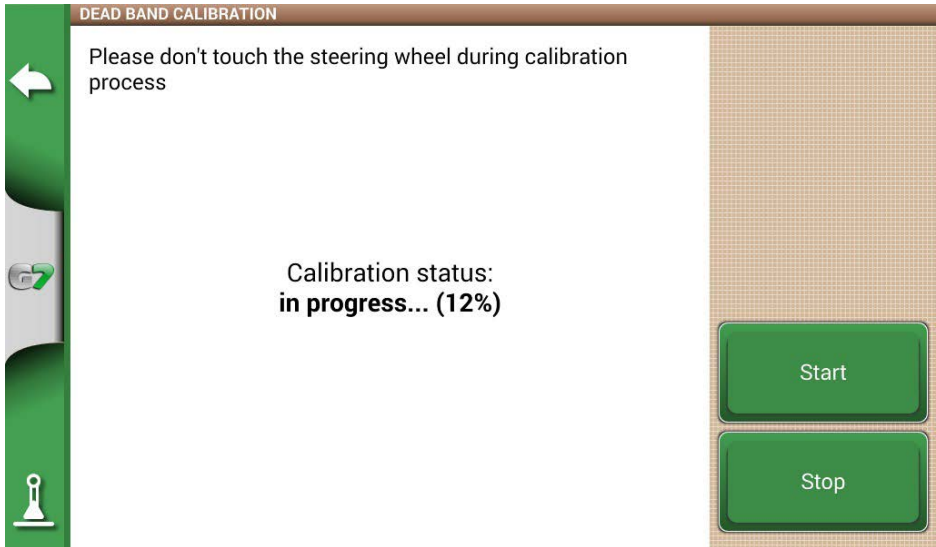

Figure 3.3.a - Dead band calibration start

2. The steering wheel starts to turn very slowly, wait until the message of successful calibration;

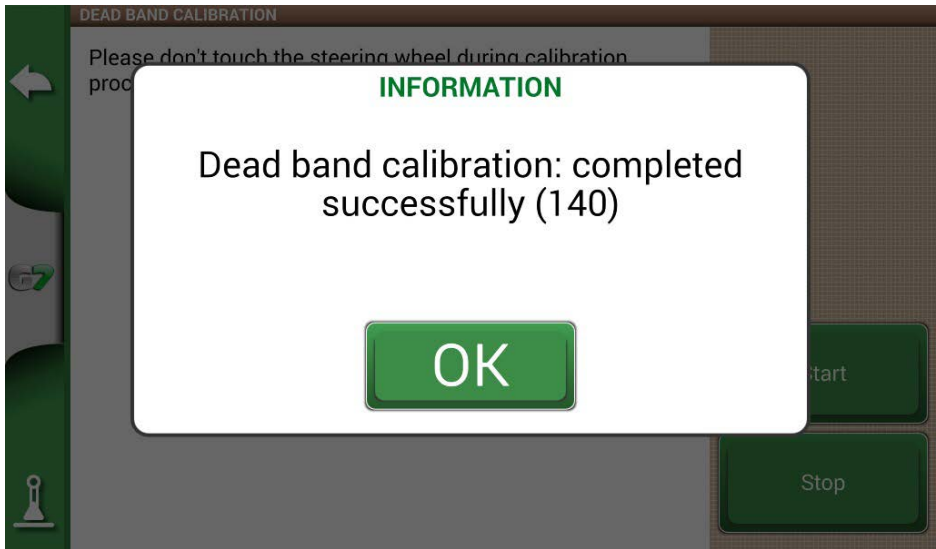

Figure 3.3.b - Successfully completed calibration

3. This calibration is found to be successful. It is possible to move on to the next one.

3.4 Steering wheel calibration

This calibration, allows the operation of the electric motor to be associated with the hydraulics and mechanics of the vehicle. It is important for defining the automatic steering performance.

Calibration must be performed:

- On a perfectly flat surface, possibly a field (200m x 200m);
- Engine 1500 RPM, speed between 4 and 8Km/h;
- Without attached implement.

During the calibration process, the vehicle will automatically make left and right turns. You can stop the calibration at any time by stopping the vehicle, turning the steering wheel or pressing the Stop button.

From the SETUP > Auto steering menu, select STEERING WHEEL CALIBRATION.

1. Align the wheels of the vehicle, then drive in a speed range of 4 to 8 km/h;
2. Press Start, DO NOT TOUCH the steering wheel during calibration;

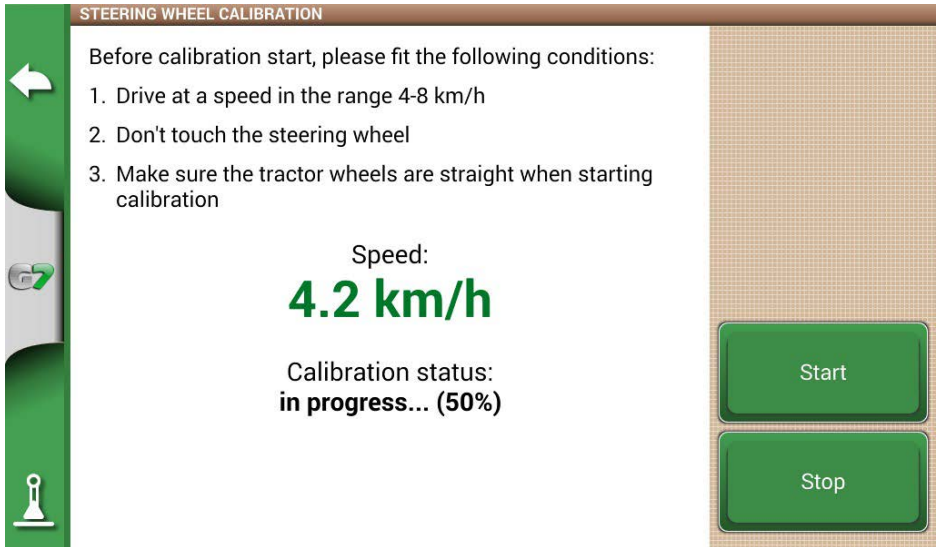

Figure 3.4.a - Steering wheel calibration start

3. Wait for the calibration to be completed;

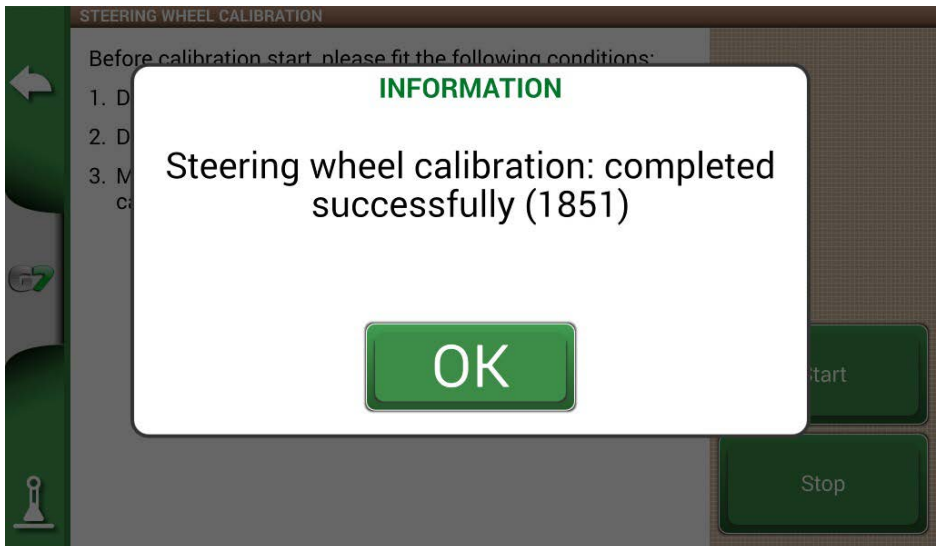

Image 3.4.b: Successfully completed calibration

3.5 Calibration of minimum turning radius

This calibration, allows the actual minimum turning radius of the vehicle to be defined.

Calibration must be performed:

- On a perfectly flat surface, possibly a field (200m x 200m);
- Speed between 4 and 8Km/h;
- Without attached implement.

During the calibration process, the operator must steer the vehicle fully to the right and left in two separate steps and wait for the calibration end message.

From the SETUP > Auto steering menu, select MIN TURNING RADIUS CALIBRATION:

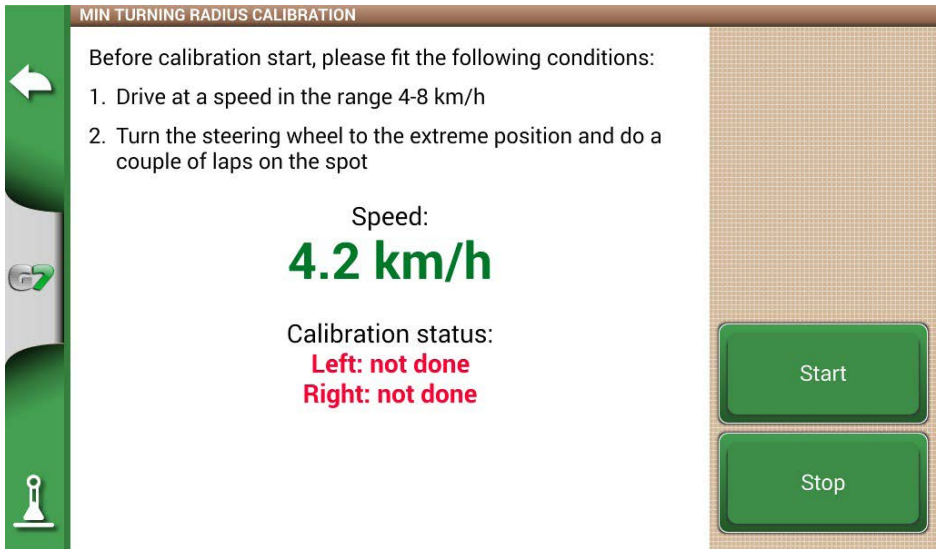

Figure 3.5.a - Successfully completed calibration

1. Align the wheels of the vehicle, then drive in a speed range of 4 to 8 km/h;
2. Press Start and then select the side to which you will start steering, such as right;

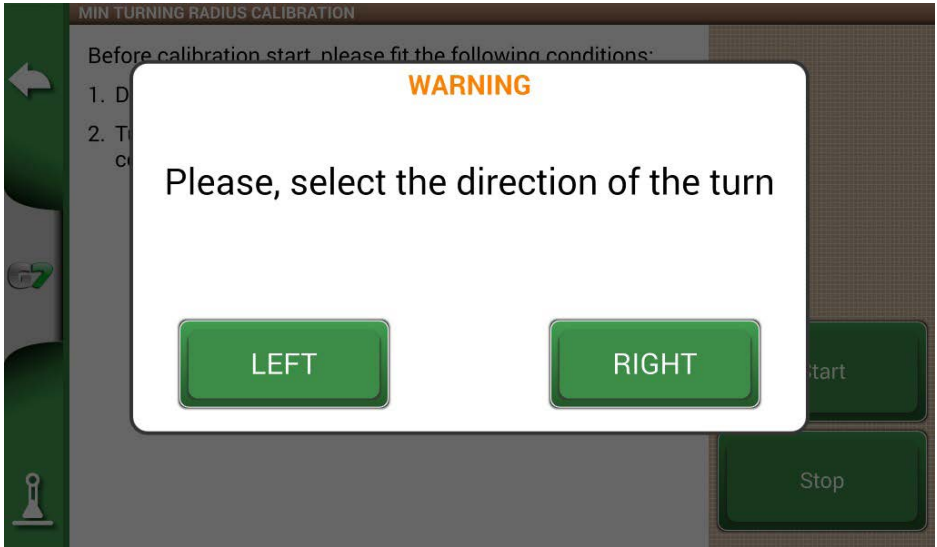

Figure 3.5.b - Select the turning direction

3. Wait for the calibration to be completed;

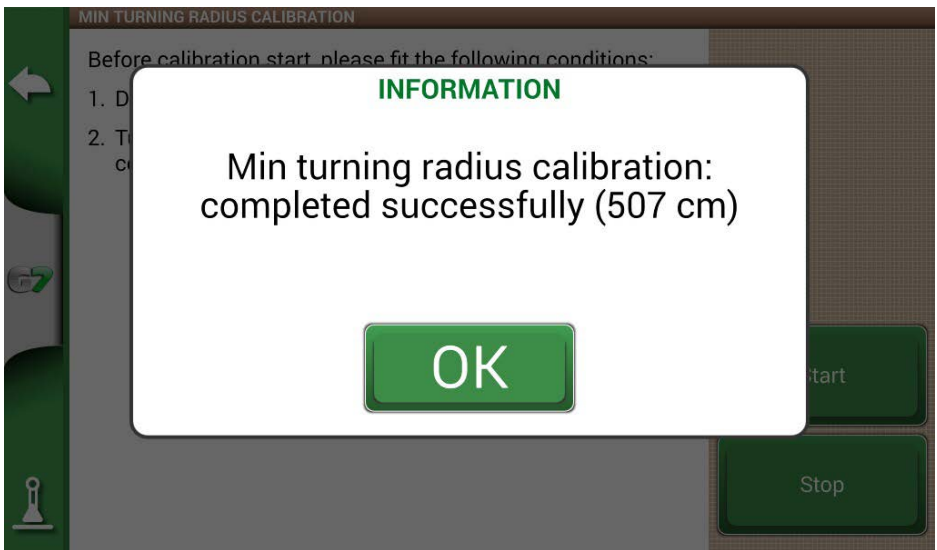

Figure 3.5.c - Calibration of the left side completed

4. Then proceed to calibration from the opposite side, then left;

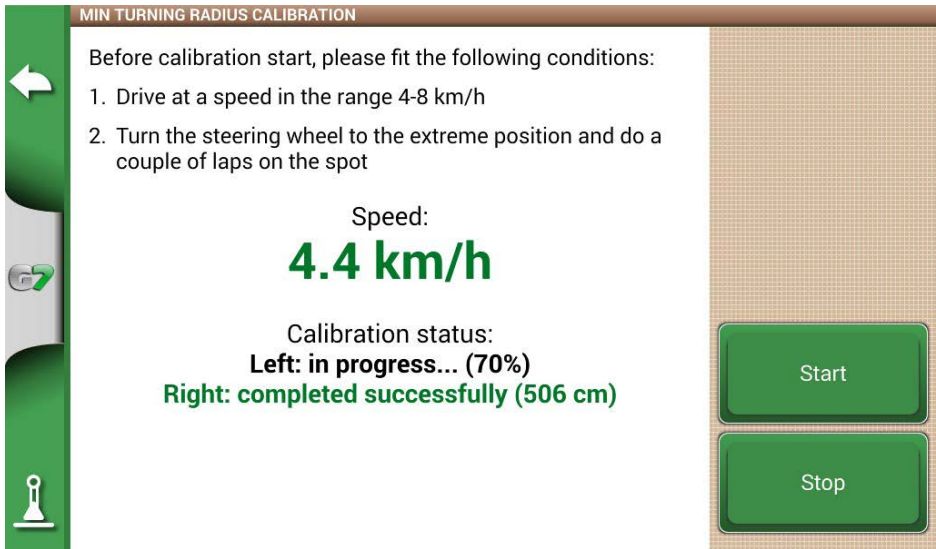

Figure 3.5.d - Right side calibration in progress

5. Then proceed to calibration from the opposite side, then right;

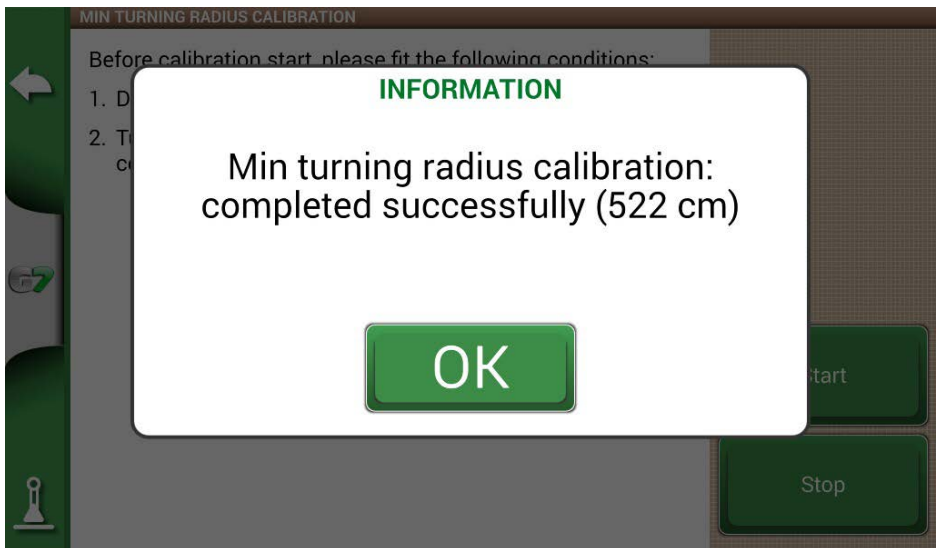

Figure 3.5.e - Successfully completed calibration

6. Calibration of the minimum turning radius is completed.

4. Field testing and adjustment of automatic steering parameters

When the calibrations are performed, the status on the configuration page is reported, as shown in the example:

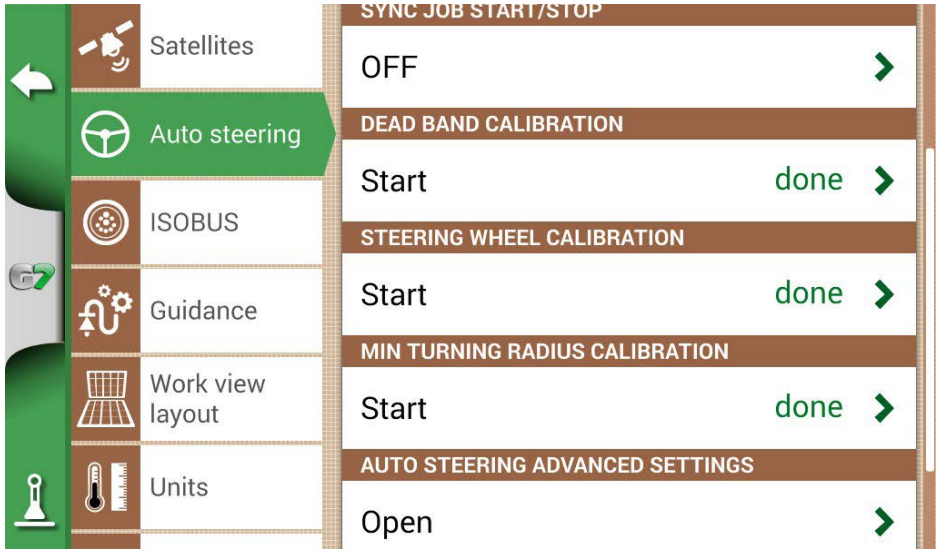
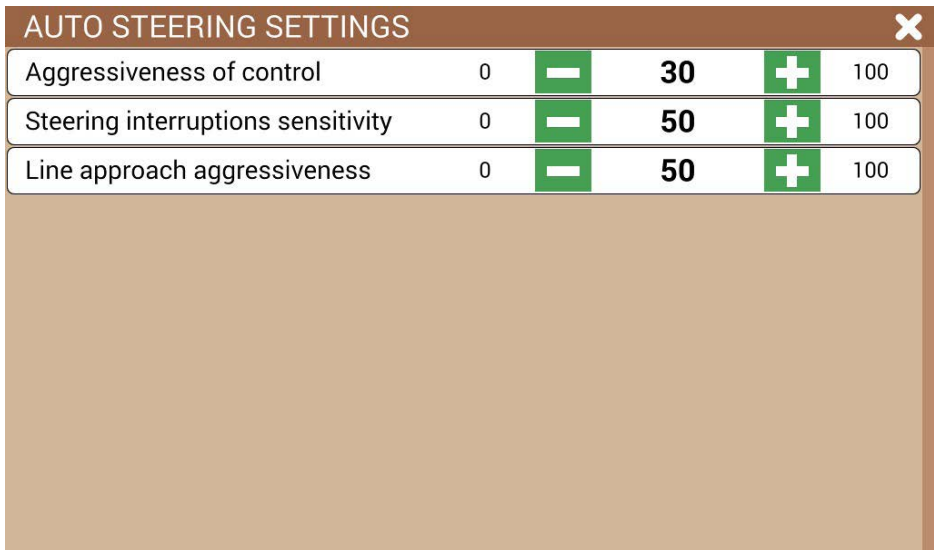

Figure 4 - Status of calibrations.

4.1 Automatic steering parameters

From the work screen, you can easily access some of the control parameters of the automatic steering system to better adapt performance while working. Below is a brief summary of the features and a tip on how to use them.

To access this window, press the white steering wheel button in the upper left corner.



AUTO STEERING SETTINGS						X
Aggressiveness of control	0	—	30	+	100	
Steering interruptions sensitivity	0	—	50	+	100	
Line approach aggressiveness	0	—	50	+	100	

Figure 4.1 - Editable parameters during the work.

- Aggressiveness of control: a value for keeping the vehicle on the line; a higher value results in more aggressive implementation, while a lower value reduces the intensity of corrections at the expense of accuracy on the line;
- Steering interruptions sensitivity: value needed to release the steering wheel from automatic to manual mode;
- Line approach aggressiveness: a value to adjust the aggressiveness of approach to the line (e.g. at the beginning of the field), a higher value implies an aggressive approach, a low value implies a gentler approach to the line.

4.2 “Round-trip” field accuracy test procedure

The following is a description of the “Round-trip” field accuracy testing procedure:

1. Creating a new Job;
2. Select or create an implement;
3. Select or create a new straight AB line (50-70 meters);
4. Then run in automatic mode the straight AB line created from B to A;
5. Stop the vehicle possibly in the middle part of the line when the error on the line shown on the screen is 0.00 +/-1cm;
6. Place a mark on the ground near the rear wheels (or in the middle of the third point);
7. Then retrace the line automatically from A to B and stop the vehicle near the ground indicator;
8. Then check the actual error between the forward pass and the return pass.

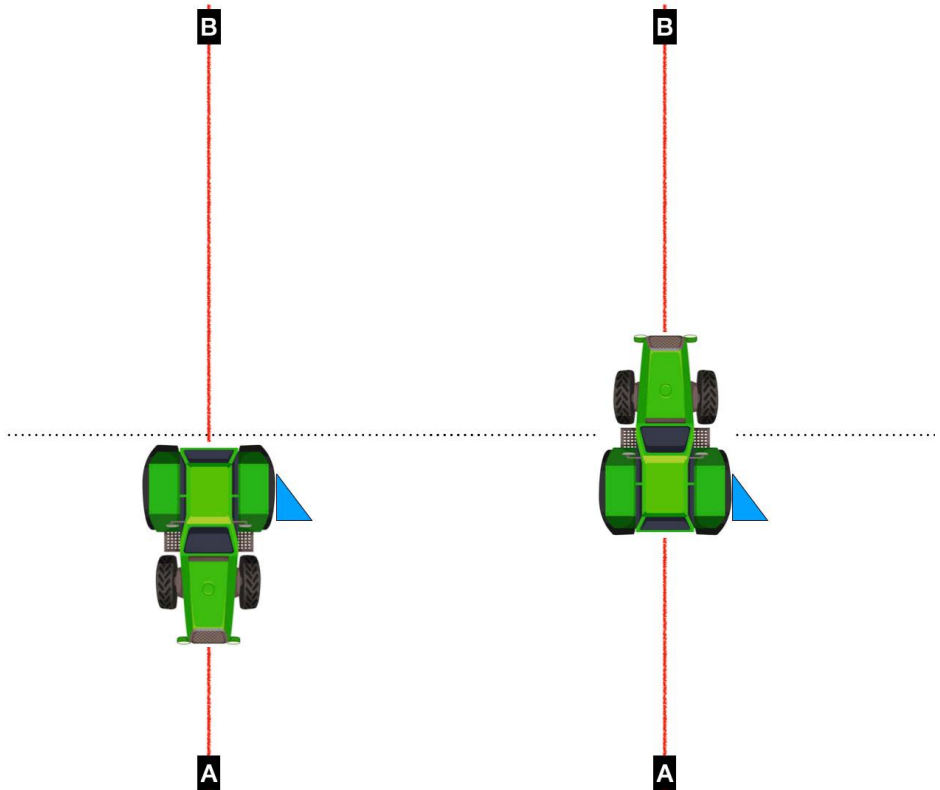
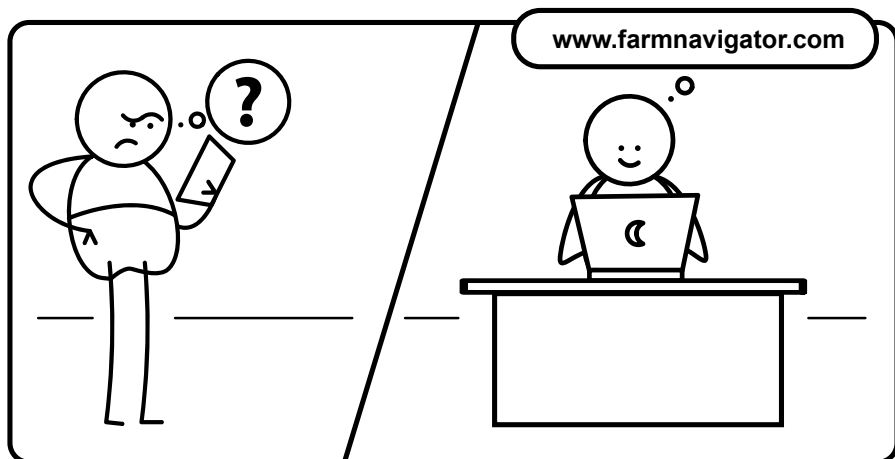

Figure 4.2 - Example of precision control between round trip.

For proper operation in the field, the error between vehicle position and ground indicator should be about +/-2cm. If not, repeat the terrain compensation calibration.



FARMNAVIGATOR

AvMap Srl
Viale Zaccagna, 6
54033 Carrara (MS), Italy
www.avmap.it
support@avmap.it

www.farmnavigator.com